

# TEACHERS' RESOURCE BOOK

# CRAZY ABOUT CORN™



# CRAZY ABOUT CORN™

## TEACHERS' RESOURCE BOOK

### What's Inside...

#### Kindergarten:

<b>Activity 1:</b> Corn—The Energy Food . . . . .	4
<b>Activity 2:</b> Corn Goes 'Round and 'Round . . . . .	8
<b>Activity 3:</b> Corn Mask-erade . . . . .	12
<b>Activity 4:</b> Corn Ear Sing-Along. . . . .	15

#### First Grade:

<b>Activity 5:</b> A Kernel of Knowledge . . . . .	19
<b>Activity 6:</b> Seeds, Seeds, Where Are the Seeds? . . . . .	23
<b>Activity 7:</b> Rootin' Tootin' Roots . . . . .	27
<b>Activity 8:</b> Tool Time. . . . .	31
<b>Activity 9:</b> Discover a Culture . . . . .	34
<b>Activity 10:</b> Say It with Sand. . . . .	38

#### Second Grade:

<b>Activity 11:</b> Corn is Born . . . . .	41
<b>Activity 12:</b> Harvest Hooplah! . . . . .	44
<b>Activity 13:</b> Corn Measures Up . . . . .	47
<b>Activity 14:</b> Blue Corn Blues. . . . .	51
Additional Resources . . . . .	55



## A Few Words About Youth

This curriculum is youth-oriented. It incorporates many learning skills to enhance youth learning.

A few activities may seem “high-tech”, but most are designed to be carried out in any environment—from the school classroom to the shade of a pickup truck in the afternoon. If some activities do not suit the needs of your group, skip around the curriculum and you will find others that do. Most activities can be presented in any sequence.

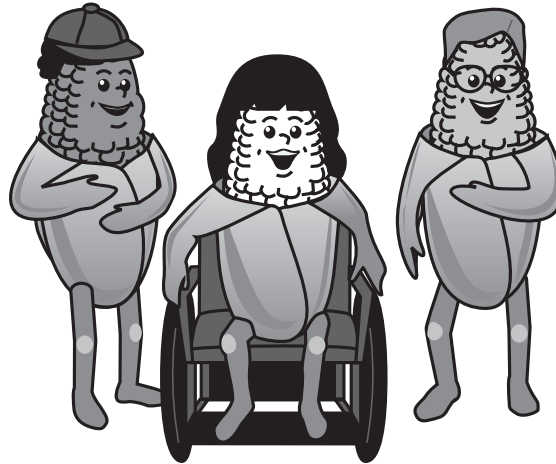

Each lesson suggests a grade level for the activities. Look for the corn symbols in the upper right-hand corner on the first page of each activity.

Under the instructions for each activity is a section, “Clues About Kids,” which offers tips for working with youth. The tips are directly related to the activity. They are provided to make your job easier and to increase the success of youth involved.

## What Is Crazy About Corn?

*Crazy About Corn* is a project designed for youth ages five through eight. Corn is the gift of gold. Through learning about one common, international food, youth will explore agriculture, literacy, nutrition, diversity, science, art, communications and horticulture. Through hands-on exploration that includes songs, stories, video, computer games and optional family involvement, youth will expand their knowledge of an important food commodity.

## Who's Who in Crazy About Corn

Activities development: Wendy Hamilton, Ed.D. and Dorothy “Dee” McLaughlin. Design and layout: Gloria Wood and Cindy Sewell. Editing: Natalie Johnson, Pamela Martinez, and Derrick Henry.

## Helper Sections

At the beginning of each activity is a “Dear Helper” section, which begins with a note to you about three things: (1) exactly what the activity is about, (2) what life skills youth will be practicing as they work through the activity, and (3) how you can determine if youth have gained knowledge from the activity.

At the end of each activity is a section called “Record Your Observations.” In this section, you can make notes about how the activity went and what youth report that they have learned. You can use these notes for a variety of purposes, such as reminding yourself of successes, recording growth among youth or reminding yourself about tips for repeating the activity.

## How Much Time Will This Curriculum Require?

There are 14 main activities to select from, and about 60 additional activities suggested for further exploration.

Groups may spend 20 minutes a day for a week on selected activities, or a whole season exploring agriculture, literacy and nutrition. 4-H clubs might use the curriculum throughout an entire club year, completing one activity per meeting. Community groups may combine several activities as part of a day camp or other educational program. The only limit is your own time.

## Resource Information

The following are examples of resources to help you complete the activities and learn more about this exciting curriculum. The Extension Service does not endorse any non-Extension publications.

**Food Guide Pyramid poster:** To order a poster of the Food Guide Pyramid write to the National Cattlemen’s Beef Association, 444 North Michigan Avenue, Chicago, Illinois 60611; phone toll-free at 1-800-368-3138. The cost is \$1.50 each if ordering 1–9 posters; \$1.25 each for 10–99; \$1.00 each for 100–999; and \$.75 each for 1,000 or more.

**2,000 Uses of Corn poster:** To order a poster listing 2,000 uses of corn, write to the Illinois Corn Marketing Board, Box 1623, Bloomington, Illinois 61702-1623. The cost is \$.60 for each poster.

**Popcorn materials:** To order a packet of teaching information and materials all about popcorn, write to The Popcorn Institute, 401 North Michigan Avenue, Chicago, Illinois 60611-4267; phone (312) 644-6610.

**Eco-foam™:** You can find Eco-foam™ for free in many of the packages shipped to your home. A packaging product made from a corn by-product, it is similar to what we call “packing peanuts.” To order a large bag of Eco-foam™, contact the American Excelsior Company, 850 Avenue H East, Arlington, Texas 76011; phone (817) 640-1555. Ask where you can find the Eco-foam™ company nearest you.

**Internet connections:** Exploring the Internet can be a valuable learning activity. Since Internet web locations frequently change, we suggest you do your own search using key words such as corn, maize, farming, agriculture, gardening, plant genetics, and vegetables.



# Corn—The Energy Food



## Dear Helper:

In this activity, youth will act out characteristics of starch and popcorn, and prepare popcorn. They will practice large-motor skills and good nutrition. After completing the activity, youth will be able to name at least one carbohydrate.

## Clues About Kids

*Set up the room to prevent problems before they happen.* When you pop the popcorn without the lid on, mark a circle 4 feet from the popper with yarn if you're on a rug or with chalk if you're on an easily marked surface. This will be an easy boundary for youth to see and use to stay away from the hot popcorn.

## Time Involved

About 20 minutes

## Suggested Group Size

Any size



## Materials Needed

Copies of Take-Along Page,

one per youth



Popcorn popper

(and oil, if needed)



Fruit juice or milk



Mats to sit on

## Vocabulary

**carbohydrate:** a nutrient in food that gives the body energy

**kernels:** the seeds of the corn plant

## Activity Resources

- *Crazy About Corn* video tape, “Cooking Corn” and “Lend an Ear” segments
- *Crazy About Corn* audio tape, “Ancient Corn Chant,” “Mexico” and “Corn Is Maize” songs

## Putting Down Roots

Corn provided energy to people for over 7,000 years. Researchers think corn originated in Mexico over 8,000 years ago and looked very different from the way it looks now. It was very small, resembled tall grass and could scatter its seeds by itself.

In 1964, scientists found corn cobs shorter than an inch in the Tehuacan Valley, not far from Mexico City. These cobs date back to ancient people, who no doubt discovered corn as an energy food and took good care of the plants.

As civilizations grew, people took **kernels** with them and planted them in new locations. New types of corn plants developed that grew larger and had more **kernels**. As the corn cobs grew, the plants could no longer seed themselves because the **kernels** could not fall away from the cob. Corn now depends on people to plant it, and people depend on corn for energy. What a combination!

Foods that give us energy are **carbohydrate** foods. These include vegetables, fruits and grains. Corn and corn products are high in **carbohydrates**.

Tell youth they will be playing games in which they pretend to be corn **kernels** breaking out of their shells.

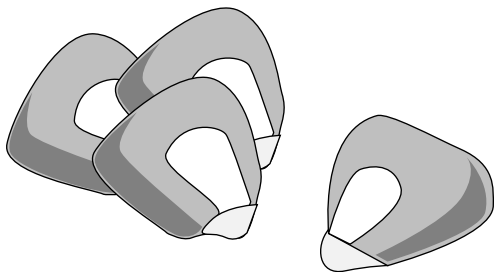

## Do It Now

1. Discuss the origins of corn and how people feel if they do not have any energy (for example tired, lazy, unable to concentrate). Explain that corn explodes through its hard shell during heating and popping.
2. Divide youth into groups of 8 to 10.

**Game 1:** Choose someone to be “**Kernel Starch**.” Tell other youth to link arms to form a hard shell. **Kernel Starch** spins around 10 times and then tries to break through the hard shell. Everybody takes a turn being **Kernel Starch**.

**Game 2:** Draw a circle in the dirt or arrange mats in a circle. Everyone sits in the circle or on the mats and pretends they are popcorn **kernels**. Youth move around in the circle or on their mats, pretending they are getting hotter and hotter, then pop out of the circle or off the mat.

3. After the games, measure out popcorn and put it in the popper. See how the **kernels** move before they pop. Catch the popping corn in bowls. (Optional: Allow the corn to pop out of the popper without the lid on. Be sure to caution youth that the popcorn will be hot, so they need to be careful and stay at least 4 feet away from the popper.)
4. Serve the popcorn with juice or milk. Eat it and enjoy the energy!
5. Review the new vocabulary.
6. Distribute copies of the Take-Along Page.

## Talk It Over

Ask youth some follow-up questions:

1. What do **kernels** look and feel like before popping?
2. Why does a **kernel** have a hard shell? (*To protect the inner grain.*)
3. Why does the **kernel** “pop”? (*Moisture in the kernel turns to steam when heated and has to escape.*)
4. How do you think you get your energy? (*You eat **carbohydrate** foods, which your body breaks down to give you energy.*)



## Seeds for More Growth

1. Discuss how you feel when you are hungry. What do you need to do?
2. Discuss which snacks give you energy. (*Snacks that are high in **carbohydrates**.*)
3. Discuss other snacks you can make with corn (*for example popcorn balls, taco shells, tortillas*).
4. Make popcorn balls and give them to your family.
5. Experiment with placing popped corn in water; observe the changes in the corn and water.
6. Soak brown or wild rice, barley and beans; see what happens to their “shells.”

## Record Your Observations

Record new skills youth have learned, comments they make and ideas for next time:

---

---

---

---

---

---

---

---

---

---

---

---



# Take-Along Page

**Activity 1:**  
Corn—The Energy Food

**Suggested Grade Level:**  
**Kindergarten**

Fruits, vegetables and grains are high in carbohydrates.

With an adult helper, use the space below to draw foods you eat that are high in carbohydrates. Label each drawing with the name of the food.

Draw an activity you do when you are full of energy.

**Q:** What did baby corn say to mamma corn?

**A:** Where's "Pop" Corn?







# Corn Goes 'Round and 'Round



## Dear Helper:

In this activity, youth will create drums and sing along with the Crazy About Corn audio tape. They will practice rhythm, communication through song, and social interaction. After completing the activity, youth will be able to name at least one reason why words and songs can complement each other.

## Clues About Kids

Say words of encouragement. As each group finishes its presentation, say something to help them build their own self esteem, such as, "The words you used made me feel happy," "Everyone in your group had a part," "How did you ever come up with that idea?" or "I'll bet you feel proud of that song."

## Time Involved

About 20 minutes

## Suggested Group Size

Divide youth into two groups



## Materials Needed

- ✓ Copies of Take-Along Page, one per youth
- ✓ Copies of words to "Ancient Corn Chant," one per youth
- ✓ Crazy About Corn audio tape, "Ancient Corn Chant" and "I Like to Eat Popcorn" songs
- ✓ Cylindrical containers, such as oatmeal or cornmeal boxes or coffee cans, one per youth
- ✓ Colored construction paper, several sheets per group
- ✓ Glue, one bottle per group
- ✓ Different-colored markers, one set per group

## Vocabulary

**round:** a short song sung at intervals (for example "Row, Row, Row Your Boat.")

**chant:** a simple melody in which a number of words are sung on each note

## Putting Down Roots

Throughout the ages people have sung **chants** and **rounds** to express emotion and to help the time seem to pass more quickly while working. **Rounds** and **chants** have also been used to remember important events. Some Native Americans believe that singing a traditional song at planting time leads to a bountiful harvest.

Tell youth they will be creating drums and singing in **rounds** (for example “Row, Row, Row Your Boat,” “Frere Jacques,” “Hickory-Dickory-Dock”). Listen to the song, “I Like to Eat Popcorn.”

## Do It Now

1. Gather materials. Give directions to youth: Cut paper to fit around the box or can. Decorate the paper. Glue the paper onto the box or can.
2. Divide youth into two equal groups. Tell groups: Form a circle with a corn drummer in the middle. Play “Ancient Corn Chant.” Practice drumming and singing to the beat. Sing in a **round**. Let one group sing the first 2 stanzas, then have the other group begin singing. Repeat this activity several times so several youth can experience being the drummer.
3. Review the new vocabulary.
4. Distribute copies of the Take-Along Page.

## Talk It Over

Ask youth some follow-up questions:

1. What other **chants** do you know?
2. What work do you do while singing a

## Activity Resources

- *Crazy About Corn* video tape, “Kids Create” and “Lend an Ear” segments
- *Crazy About Corn* audio tape, “Ancient Corn Chant,” “Corn Is Maize” and “I Like to Eat Popcorn” songs

**chant?** (for example cleaning up, story time, lunch)

3. Why do you like to sing in a **round**?
4. What other instruments do you think would work with the drums?  
(for example, harmonica, kazoo, tambourine, bells)

## Seeds for More Growth

1. Discuss how work is easier when you are singing.
2. Discuss if house plants are “happier” when you sing to them.
3. Make some instruments using common household items (for example pots and pans, paper towel rolls, empty boxes and rubber bands). Create your own marching band and sing a **chant**.
4. Visit a Native American festival or listen to tapes of Native American music. Make a list of words describing what you think about when you hear the music.
5. Research other **chants**. Choose one to practice and perform for a larger group.
6. Make up your own group **chant** to sing while working.





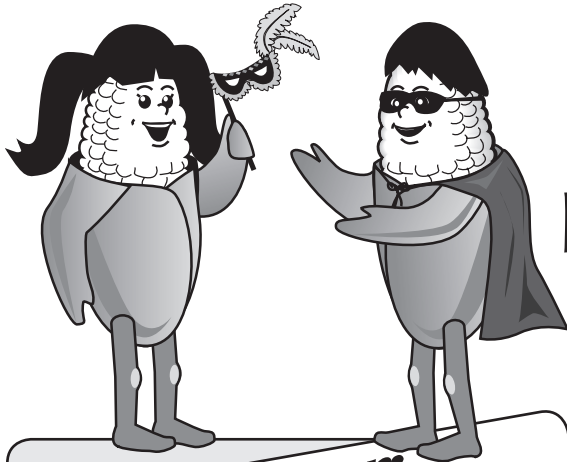

# Corn Mask-erade



## Dear Helper:

In this activity, youth will make masks. They will practice fine-motor skills and artistic exploration. After completing the activity, youth will be able to display their masks and identify at least one difference between pretending and reality.

## Clues about Kids

*Reinforce children's abilities.* Allow youth to work on their masks. Masks may not turn out exactly as the children pictured. They may not be perfect as the ones in a store. Say, "This mask is like no other mask in the room. There's no other one like it in the whole world because it was made by you, and that makes it one of a kind."

## Time Involved









About 20 minutes

## Suggested Group Size

Any size



## Materials Needed

-  Copies of Take-Along Page, one per youth
-  Corn husks, enough to provide several leaves per youth
-  Scissors, to share
-  Glue, to share
-  2 feet of 1/4-inch-wide colored ribbon per mask
-  8-1/2-inch x 11-inch cardboard, one piece per youth
-  Colored markers, one set per group
-  Hole punch, to share

## Vocabulary

**husk:** dry, protective outer covering of certain fruits or vegetables

**pretend:** to act out in a play; make-believe

**represent:** to serve as a symbol

## Putting Down Roots

“Let’s **pretend**.” What exactly does that mean to you? Costumes help get a story message across and help the characters come alive.

Discuss characters and costumes from popular movies and stories. Show how the visual image helps the story seem real.

Ask questions such as:

1. What type of clothes do characters wear in western movies?
2. How do the horses and the kind of clothes worn make it easier for you to **pretend** the story is a western?
3. If I dressed up like a butterfly (imitate flying around the room), would you think that I was **pretending** to be a butterfly?
4. If I were wearing a mask of a pirate, why would it be easier for you to believe I am a pirate?

Tell youth they will be making a mask out of cardboard and corn **husks**.

## Do It Now

1. Ask youth to pass out **husks**, cardboard and other materials. Encourage use of materials in creative and unique ways.
2. Give directions to youth: Make any kind of mask you choose. Cut out the cardboard to make holes for the eyes. Decorate your masks with **husks**. Attach ribbon so that the mask can be tied securely. Wear your mask and display it to the group.
3. Review the new vocabulary.
4. Distribute copies of the Take-Along Page.

## Activity Resources

- *Crazy About Corn* video tape, “Cornfield Classroom” and “Lend an Ear” segments
- *Crazy About Corn* audio tape, “Corn Matters Most of All” and “Peek-a-Boo” songs

## Talk It Over

Ask youth some follow-up questions:

1. What kind of mask did you make? Why?
2. How do you think a mask helps in **pretending**, to show others something different or **represent** something or someone else?

## Seeds for More Growth

1. Make a corn **husk** doll using additional **husks**.
2. Make corn **husk** place mats for yourself and family members.
3. Make tamales using corn **husks**.

## Record Your Observations

Record new skills youth have learned, comments they make and ideas for next time:

---

---

---

---

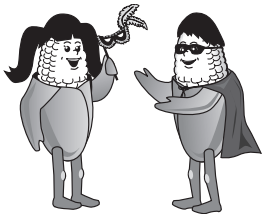

# Take-Along Page

**Activity 3:**  
Corn Mask-erade

**Suggested Grade Level:**  
**Kindergarten**

With an adult helper, use supplies in your home to make family masks. Here is a pattern idea:

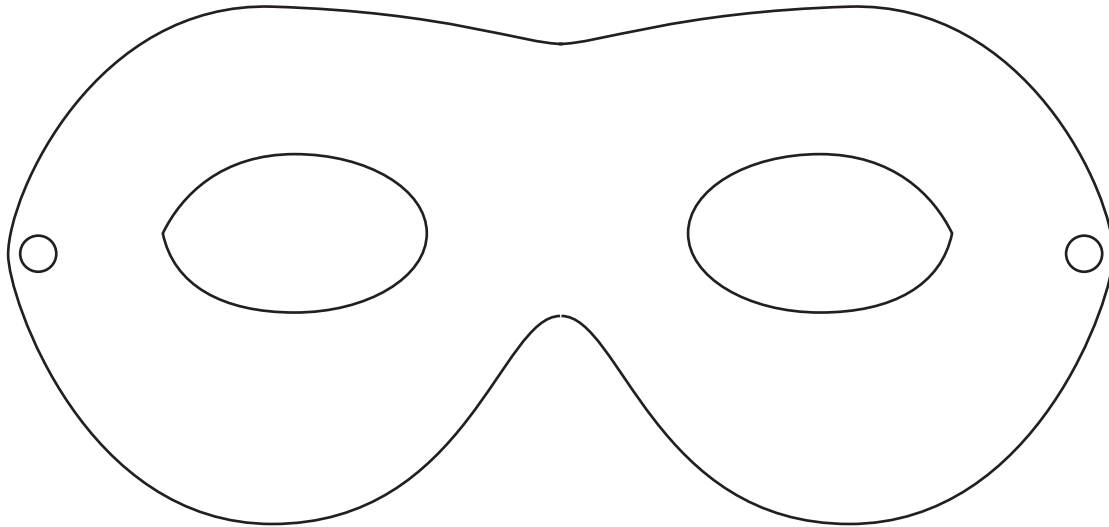

Knock, knock. *Who's there?*  
*Corn. Corn who?*  
*Corn you come out and play with me?*

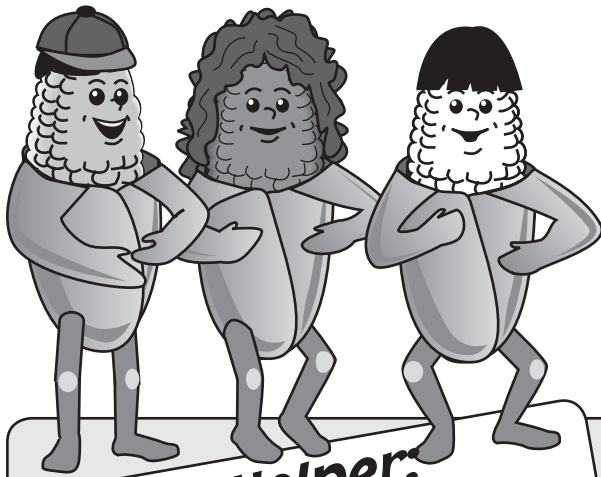

# Corn Ear Sing-Along



## Dear Helper:

In this activity, youth will practice singing. They will learn music appreciation through practicing rhythmic motions. After completing the activity, youth will be able to demonstrate at least one motion from the song.

## Clues About Kids

Help children to get involved and to have fun. It will take a couple of tries for children to learn the song and the hand motions. Keep smiling and laughing and having fun even if the children don't learn all the words or motions perfectly. The activity will be similar to how people dance to the "Macarena": most people don't do it exactly right but they still laugh and have a good time. Children will pick up on the sing-along more quickly if they're enjoying what they're doing.

## Time Involved

About 15 minutes

## Suggested Group Size

Any size



## Materials Needed



Copies of the Take-Along Page, one per youth



"Corn Ear Sing-Along" song on the *Crazy About Corn* audio tape

Tape player

## Vocabulary

**corn silk:** long, silky fibers on an ear of corn

**tassel:** branched flower at the top of a stalk of corn

**generation:** group of individuals born and living at about the same time.

## Activity Resources

- *Crazy About Corn* video tape, "Lend an Ear" segment
- *Crazy About Corn* audio tape, "Corn Ear Sing-Along," "Blue Corn Blues" and "What Matters Most of All" songs





# “Corn Ear Sing-Along” Hand Motions

1

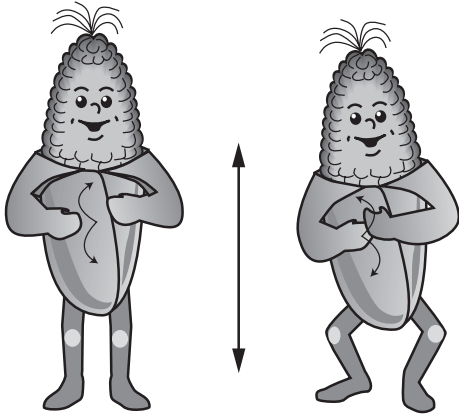

“Lots and lots of little kernels  
make an ear of corn.”

*(hands cupped, moving up and down along body)*

2

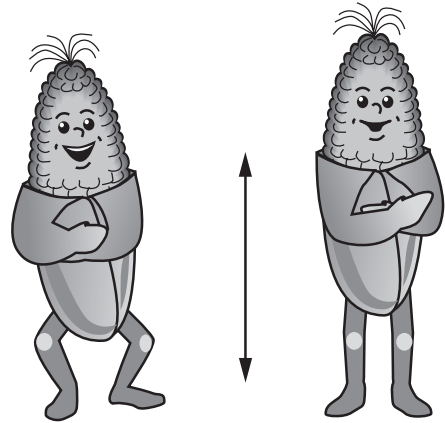

“Wrapped up in my shiny husk”

*(arms folded around body,  
turning body slightly left to right)*

3

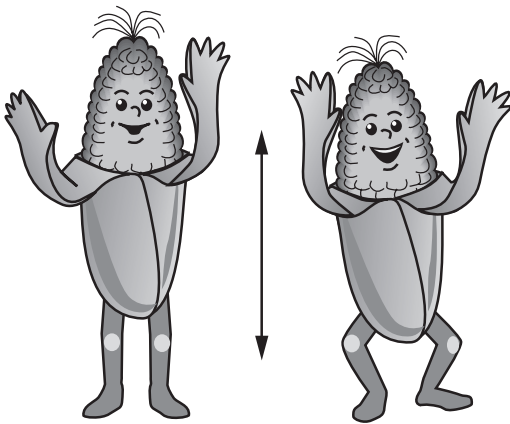

“I wake up in the morning.”

*(arms up, fingers spread, swinging side to side)*

4

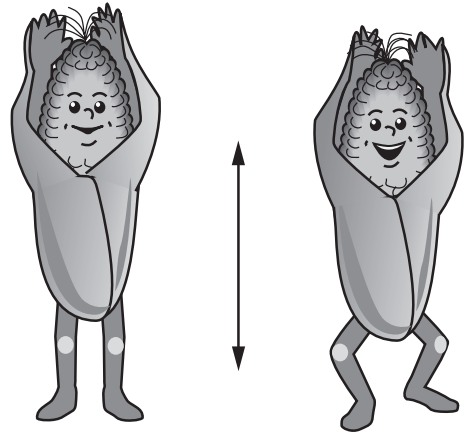

“I have a tassel on my head;  
it turns brown when I’m grown.”

*(arms up, fingers spread, moving to and fro)*

5

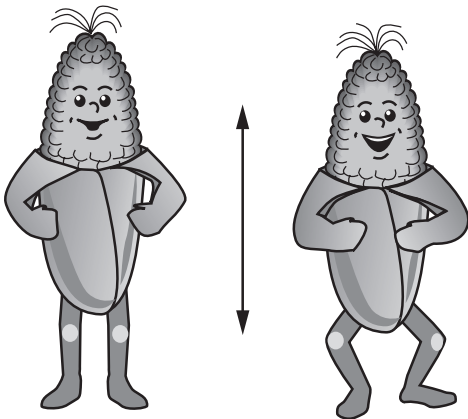

“Now it’s time to leave the farm.”

*(arms bent, moving up and down)*

6

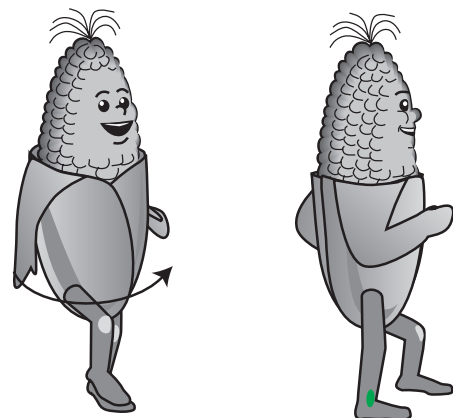

“I’m going in to town.”

*(turn and march in place)*

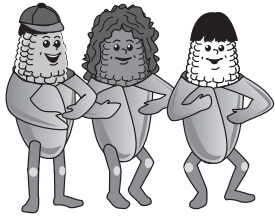

# Take-Along Page

## Activity 4: Corn Ear Sing-Along

**Suggested Grade Level:  
Kindergarten**

Try these “Corn Ear Sing-Along” hand motions with your family—bouncing up and down, bending knees and then standing, or swinging side-to-side through the song.

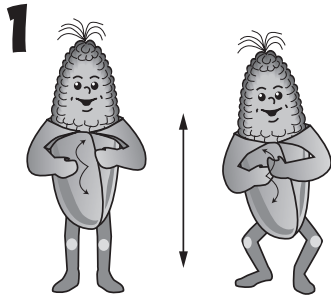

“Lots and lots of little kernels make an ear of corn.”  
*(hands cupped, moving up and down along body)*

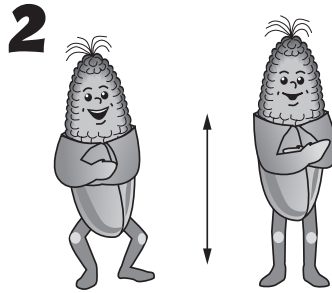

“Wrapped up in my shiny husk” *(arms folded around body, turning body slightly left to right)*

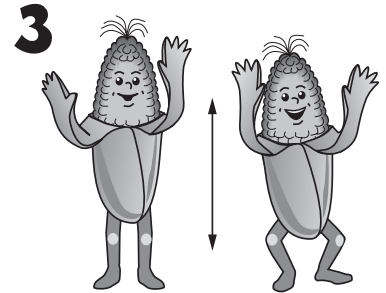

“I wake up in the morning.” *(arms up, fingers spread, swinging side to side)*

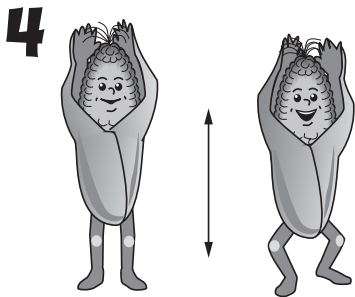

“I have a tassel on my head; it turns brown when I’m grown.” *(arms up, fingers spread, moving to and fro)*

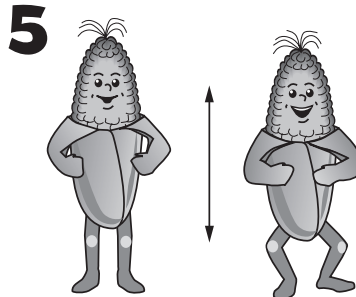

“Now it’s time to leave the farm.” *(arms bent, moving up and down)*

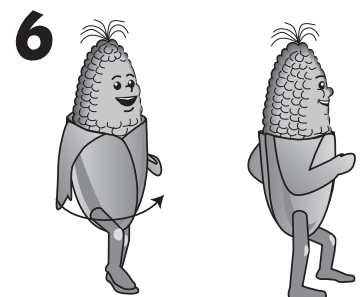

“I’m going in to town.” *(turn and march in place)*

**Q:** What has ears but can’t hear?  
**A:** A stalk of corn.

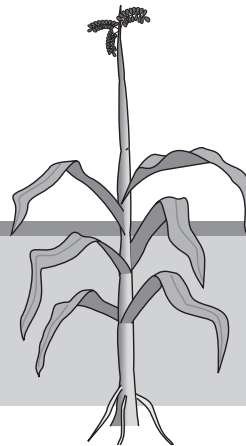



# A Kernel of Knowledge



## Dear Helper:

In this activity, youth will each create a page for a group book about corn. They will practice literacy skills and fine-motor skills. After completing the activity, youth will be able to talk about the page they created.

## Clues About Kids

*Model encouragement.* Tell each child something about his or her part of the book, such as “You came up with a really neat idea.” This helps children build self-esteem and shows them how to treat one another.

## Time Involved

About 25 minutes

## Suggested Group Size

Three to five per group

## Materials Needed

 Copies of Take-Along Page, one per youth

 Copies of “The Roots of Corn” poem (see Activity 11), one per youth



Corn storybook patterns, one per youth



Yellow yarn, 2 feet per page of corn book



Large-eyed needle, one per youth



Hole punch, to be shared by all



Pencils, one per youth



Scissors, one per group



Markers, one set (several different colors)



List of story starters (see “Do It Now” section of this activity)

## Vocabulary

**fiction:** writing that deals with imaginary characters or events

**nonfiction:** writing that deals with real or historical characters or events

**author:** person who writes a book

**illustrator:** person who creates pictures for books

## Putting Down Roots

Share several different corn stories and other popular children's books (see Additional Resources in the back of this booklet). Corn and its uses around the world are discussed in books such as *Corn Is Maize* and *The Popcorn Book*.

Discuss with the group what is appealing about certain **authors'** works. Brainstorm to come up with words about corn, and post these in the room. Enlarge and duplicate the corn storybook pattern (see page 21).

Tell youth they will be writing and **illustrating** a book to share with family and friends.

## Activity Resources

- *Crazy About Corn* video tape, "Lend an Ear" segment
- *Crazy About Corn* audio tape, "I Like to Eat Popcorn," "Peek-a-Boo," "Growing Up Fast," "I Love My Corn" and "Corn Aria" songs

Refer to Additional Resources in the back of this booklet for ideas on books to share with children.

## Do It Now

1. Tell youth to cut out the corn storybook pattern. Using one of these story starters, youth or helper can write the corn story:

- "Corn is used for . . ." *(products and foods)*
- "Corn is grown . . ." *(sequence of corn growth from seeds to harvest)*
- "I like corn because . . ." or "Corn is yummy with . . ." *(ways to combine foods into snacks or meals; for example, popcorn with cheese, or tacos with beans and salsa, or cornbread with honey).*

2. **Illustrate** the pages using crayons or markers.
3. When done writing and **illustrating** the pages, it is time to make the binding:

Punch holes for yarn, and use yarn to lace up the pages around the edges. Connect the pages to make a group book.

4. Review the new vocabulary.
5. Distribute copies of the Take-Along Page.

## Talk it Over

Ask youth some follow-up questions:

1. What are the different jobs people do when they work together to make a book?
2. How does creating a book help you to remember information?
3. Could you use a computer to make a book? How would it be like a handmade book? How would it be different?

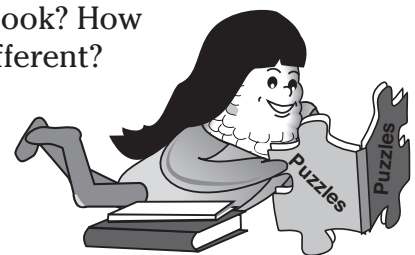

## Seeds for More Growth

1. Discuss other books about plants that you enjoy.
2. Discuss other ideas for a corn story. What different shapes could the book be?
3. Write a book about where you live, explaining why you like or do not like living there.
4. Make a book in the shape of a different vegetable, fruit or animal.

## Record Your Observations

Record new skills youth have learned, comments they make and ideas for next time:

---

---

---

---

---

---

---

---

---

---

## Corn Storybook Pattern

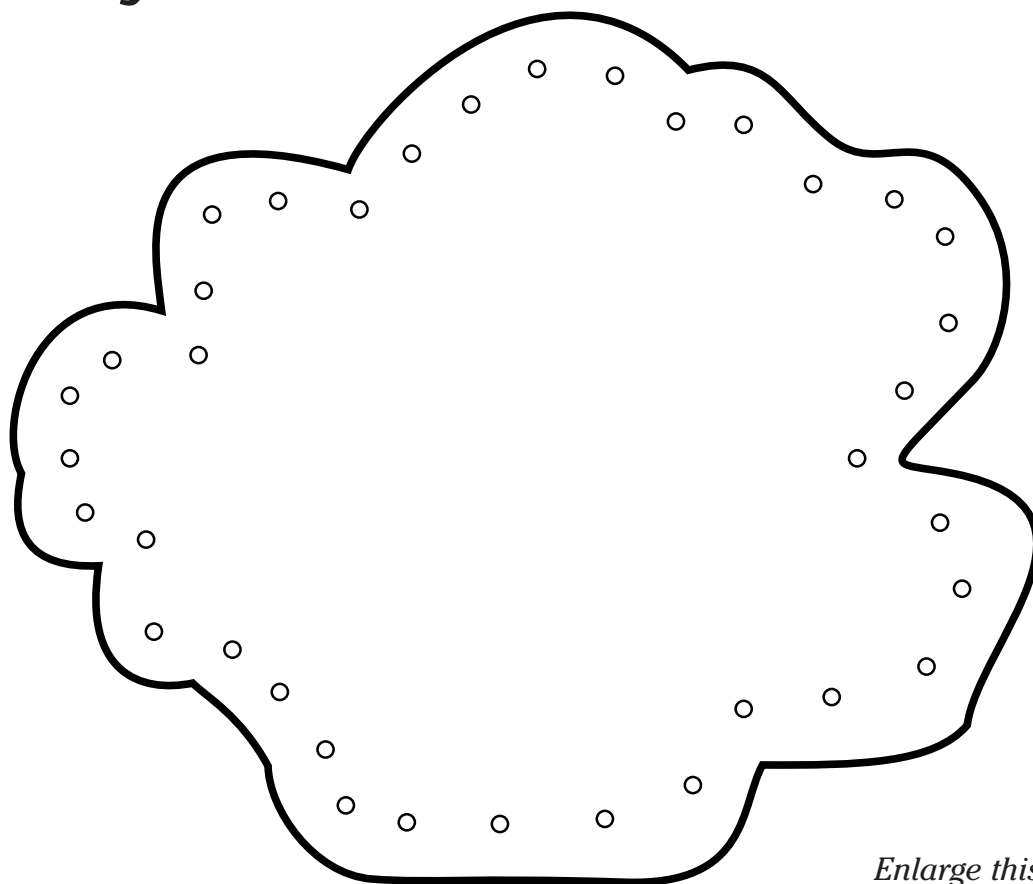

*Enlarge this pattern*



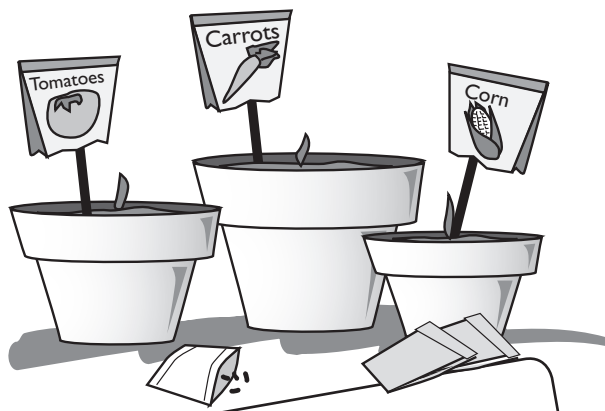

# Seeds, Seeds, Where Are the Seeds?



## Dear Helper:

In this activity, youth will prepare and decorate a seed pot. They will practice experimentation skills, explore cause-and-effect relationships, and practice artistic expression. After completing the activity, youth will be able to describe at least one type of seed-storage container.

## Clues About Kids

*Pay attention to all of the children.* Notice if all children get a chance to answer questions. If one child is answering all the questions or another child never talks, try to even up participation.

Ask a child who rarely talks to help you carry supplies to the table. Ask another one who frequently talks to pick others to answer the questions.











## Time Involved

About 25 minutes

## Suggested Group Size

Any size

## Materials Needed

-  Copies of Take-Along Page, one per youth
-  Corn seed varieties (white, red, speckled, yellow, blue, purple)
-  Cardboard egg cartons, one per youth
-  Clear glass jar (12-ounce or larger size)
-  Variety of small storage containers (bags, boxes, plastic)
-  Scissors, one pair per youth
-  Small plastic jar (4-ounce size), one per youth
-  Labels for small plastic jars
-  Glue, to be shared by all
-  Markers, to be shared by all

## Vocabulary

**annual:** a plant that lives and grows for only one season or year

**perennial:** a plant that has a life span of more than two years



## Putting Down Roots

**Perennial** plants grow every year without being planted again. Some of these are crops like grass and alfalfa, some are flowers and many are fruits and nuts. **Annual** plants, such as corn, must be planted every year.

In order to have seeds to plant, farmers save seeds from the previous year's harvest. There are many different ways of storing seeds to keep them cool, dry, in the dark and away from bugs and other animals.

When new types of corn are developed, the seeds must be saved to test the new crops. Testing crops helps to ensure that the corn is healthy and disease-resistant. It also shows what conditions are needed to produce large harvests.

Tell youth they will be preparing and decorating a seed pot.

## Activity Resources

- *Crazy About Corn* video tape, "Cornfield Classroom" and "Lend an Ear" segments
- *Crazy About Corn* audio tape, "Ancient Corn Chant" and "Corn Is Maize" songs

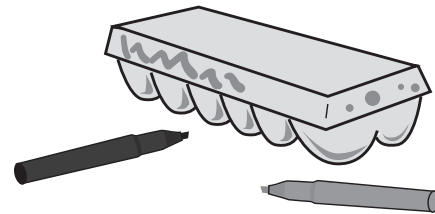

## Do It Now

1. Have youth distribute egg cartons. Put a few corn seeds in each section and tape the carton closed. Pour water over it. Ask youth about what effect water has on cardboard.
2. Youth can repeat the experiment with a variety of styrofoam and plastic containers.
3. Discuss the advantages and disadvantages of different kinds of containers. Explain that size and durability should be considered in choosing a container. Colored plastic may be a good choice because it can keep seeds dry, cool and protected from the light.
4. Distribute one plastic container per youth. Give directions to youth: Cut out paper labels and decorate them using corn seeds and markers. This will help block sunlight. Glue the label to your plastic jar, put your seeds in and save the seeds.
5. Review the new vocabulary.
6. Distribute copies of the Take-Along Page.

## Talk It Over

Ask the group some follow-up questions:

1. How long do you think your corn will be preserved in the seed pots? (*Light, heat and moisture will all affect preservation.*)
2. Why would farmers need larger seed pots than the ones you made?

## Seeds for More Growth

1. Arrange to visit a seed bank to see what grows well in your area. Call your county extension service, a local garden nursery or the Department of Agriculture to locate a nearby seed bank.
2. Discuss how food, clothes or toys can be stored for later use.
3. Discuss: "Instead of storing corn seeds, if you have extra money and 'store' it in a jar or a bank, will it be there when you need it later?"
4. Make a carton for holding favorite hobby items or keepsakes. Decorate the carton so that anyone who sees it will know what is inside.
5. Start a seed collection. Dry the seeds and put them in a seed pot; plant them next spring.

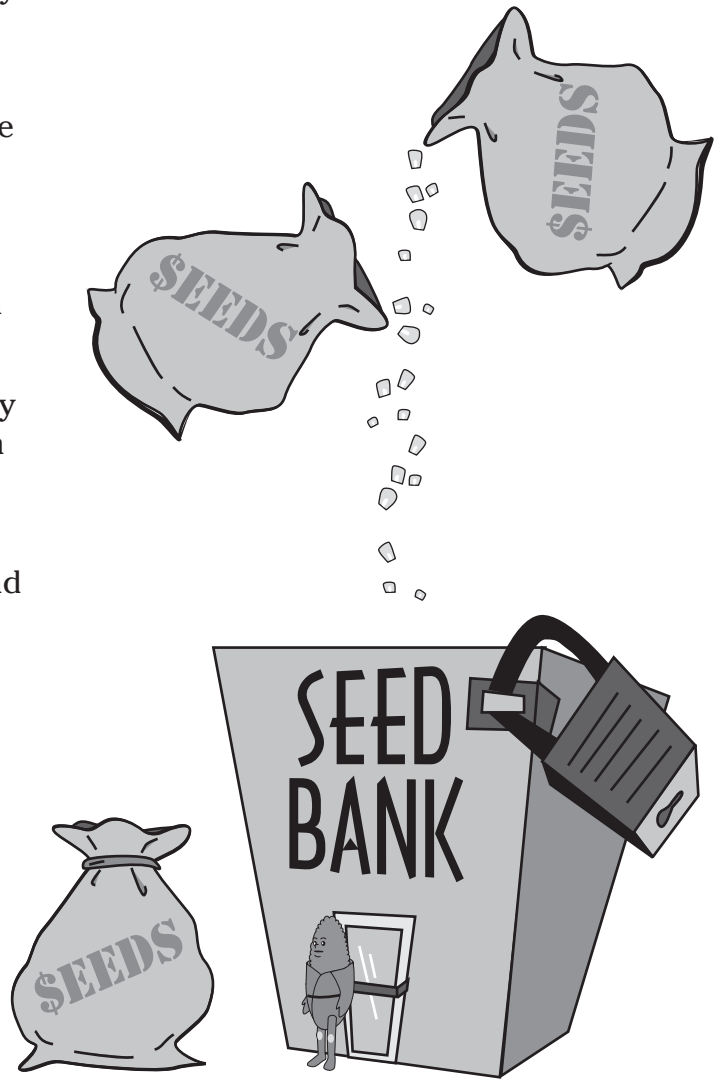

## Record Your Observations

Record new skills youth have learned, comments they make and ideas for next time:

---

---

---

---

---

---

---

---

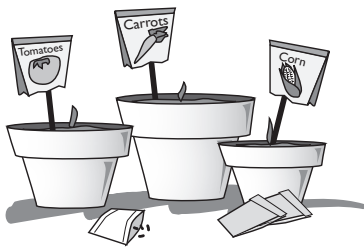

# Take-Along Page

**Activity 6:**  
Seeds, Seeds, Where Are the Seeds?

**Suggested Grade Level:**  
**1st Grade**

Grow corn in a bag.

## What you will need

1. 5–6 corn kernels
2. paper towels
3. 1 sandwich-size zipper-lock bag
4. water
5. black markers

## Directions

1. Wet a paper towel completely, then wring out excess water.
2. Put 5–6 kernels in the center of the paper towel. (*This many kernels will increase the chances of sprouting.*)
3. Put the paper towel—with the kernels—in the zipper-lock bag so the kernels can be seen. Close the bag and label it.
4. Lay the bag in a place exposed to natural daylight, or a grow lamp, where you can observe it.
5. Check on the bag regularly, water the kernels and watch the corn grow. (*When the corn grows too tall for the bag, unzip the top.*)

**Q:** What did one baby corn say to the other baby corn?

**A:** The stalk brought me.





# Rootin' Tootin' Roots

1st Grade

## Dear Helper:

In this activity, youth will observe the force of gravity on a root system. They will practice experimentation and make observations over time. After completing the activity, youth will be able to describe one effect of gravity on plants.

## Clues About Kids

Help children think of ways to remember to check containers every day for five days. Maybe they can brainstorm ideas and come up with a signal or reminder. For example, children could check the containers when they arrive or after their snack.

## Time Involved

15 minutes initially; 5 minutes daily thereafter for 5 days

## Suggested Group Size

Two to four per group

## Materials Needed

- ✓ Copies of Take-Along Page, one per youth
- ✓ Clear plastic wrap
- ✓ 5-inch x 5-inch x 1-inch unbreakable containers with lids, or styrofoam meat trays with plastic wrap, one per group
- ✓ Paper towels, enough to fill each container
- ✓ Sprouted corn seeds (about 2 weeks old), 4–5 per container
- ✓ Root beer or other water-based liquid, at least 1 qt.

## Vocabulary

**roots:** lower part of a plant that anchors the plant to the soil, stores food and absorbs water and nutrients

**gravity:** a pulling force that the earth exerts on bodies at or near its surface

## Putting Down Roots

Plants may not travel long distances, but their **roots** do! **Gravity** not only pulls **roots** and other objects toward the earth; it also keeps us all from floating away into space.

Sprout seeds before this activity as shown in Activity 6 Take-Along Page, ensuring that the **root** system is visible.

Tell youth they will be observing the effects of **gravity** on a root system.

## Activity Resources

- *Crazy About Corn* video tape, “Cornfield Classroom” and “Lend an Ear” segments
- *Crazy About Corn* audio tape, “Immigrant Song” and “Mexico” songs

## Do It Now

1. Give directions to youth: Soak the paper towels with root beer or other water-based liquid. Place the sprouted seeds into the container. Seal the container tightly with plastic wrap. Set the container on its side so that the **roots** point away from the ground. Place a mark on the side that faces down. Turn container in a different direction every other day (page 29). Check the container every day for five more days and observe the direction in which the roots are growing.
2. Review the new vocabulary.
3. Distribute copies of the Take-Along Page.

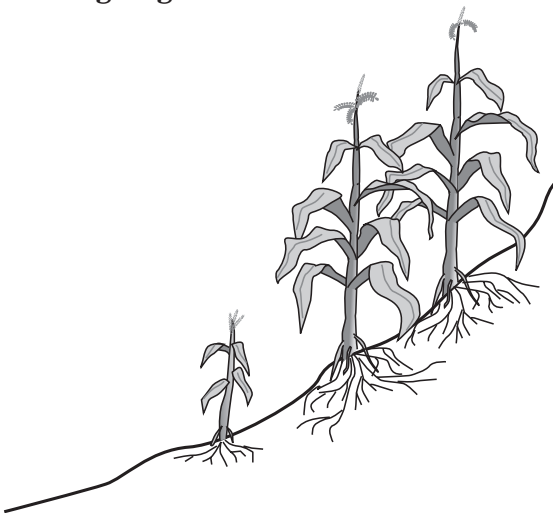

## Talk It Over

Ask youth some follow-up questions:

1. In which direction did the **roots** grow? (*They grew downward.*)
2. Did some of the corn grow differently? (*All grew toward the ground*)
3. If you planted the corn in the ground, how would **gravity** affect the **roots**? (*They would grow downward because **gravity** is a pulling force.*)
4. What else is affected by **gravity**?

## Seeds for More Growth

1. Discuss whether other plants grow in different directions.
2. Discuss why the **roots** of a plant would change directions.
3. Discuss how and why plants growing on the sides of hills hold soil in place with their **roots**.
4. Try the original activity with other types of seeds. Compare the results.

5. Roll two marbles down a piece of cardboard at the same time, then change the angle of the cardboard and roll them down again. Ask “What did you observe? Do the marbles go down the board faster at different angles? How do the marbles demonstrate the force of **gravity**?”
6. Instead of rolling marbles, pour water down a flat piece of plastic or metal, then change the angle of the plastic or metal and pour the water again. Ask “What did you observe? Does the water travel faster at different angles?”

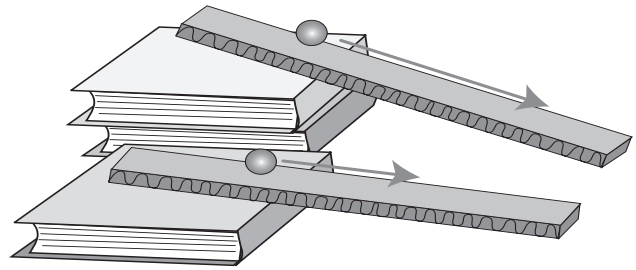

## Record Your Observations

Record new skills youth have learned, comments they make and ideas for next time:

---



---



---



---

### How to Turn Trays

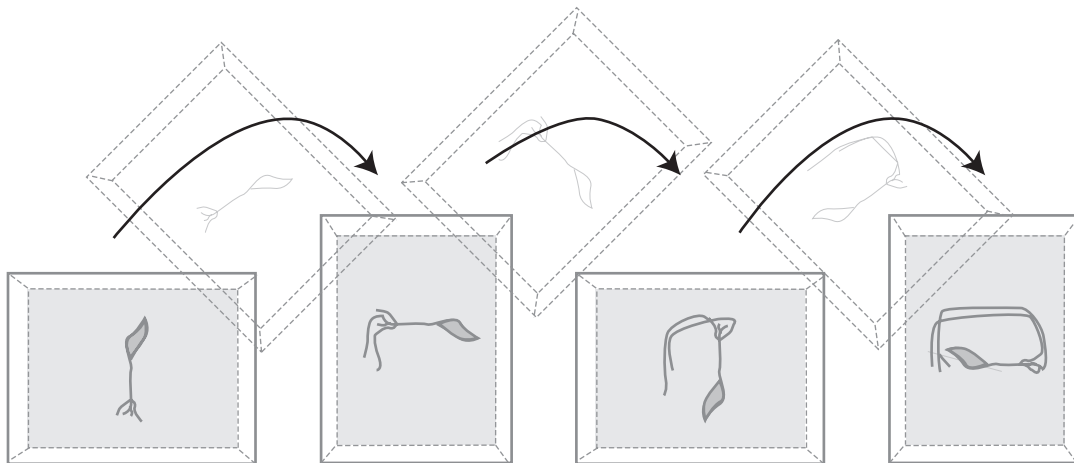



# Take-Along Page

## Activity 7: Root'n Toot'n Roots

**Suggested Grade Level:**  
**1st Grade**

Build a root display.

With an adult helper, collect some root samples from different plants in your yard or a local field or park. Mount the plants on cardboard for display.

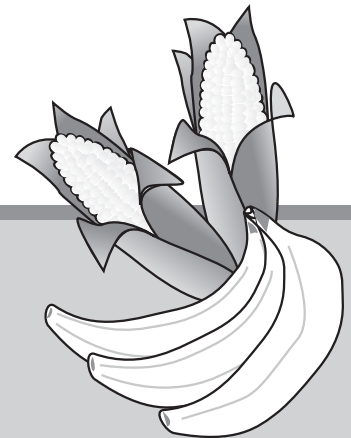

**Q:** What do you get when you cross corn with bananas?

**A:** Cornanas!

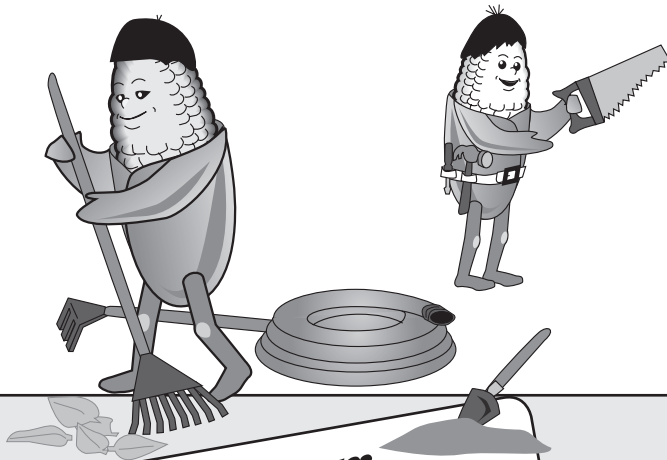

# Tool Time

## Dear Helper:

In this activity, youth will learn about the uses of gardening tools. They will practice learning-to-learn skills. After completing the activity, youth will be able to state the name and use of at least one tool.

## Clues About Kids

*Help children respect one another.* Some children may tease others who give the wrong answers. Teasing can cause some children to give up on trying to answer the questions. Even when children give the wrong answer, say something positive to discourage teasing. For example, say “You’re close, but that’s not exactly the answer I’m looking for,” or “Good try,” or “That’s an interesting answer. Are there any other ideas to share?”

## Time Involved

About 15 minutes

## Suggested Group Size

Any size

## Materials Needed

- ✓ Copies of Take-Along Page, one per youth
- ✓ A variety of garden tools, borrowed from a neighbor, a hardware store or a garden store; or pictures of tools cut from gardening magazines
- ✓ Markers and papers, one set per group (for tool drawings)

## Vocabulary

**tool:** something that helps you do work, such as saws, hammers, rakes and hoes

## Activity Resources

- *Crazy About Corn* video tape, “Tooling Along” and “Lend an Ear” segments
- *Crazy About Corn* audio tape, “Growing Up Fast” and “Blue Corn Blues” songs



## Putting Down Roots

Similar types of **tools** have been used for hundreds of years to grow corn on farms and in gardens.

Tell youth they will be playing a question-and-answer game about the uses of different gardening **tools**. They will also be practicing how to hold and use the **tools**, or drawing pictures that show the use of one or more of the **tools**. Discuss safety rules for tools.

## Do It Now

1. Hold up a **tool**. Let youth respond individually to the question, "What is this used for?" Continue this question-and-answer game until you have displayed and discussed all of the **tools**.
2. Tell youth they may try out the **tools** or draw pictures of them being used.
3. Review the new vocabulary.
4. Distribute copies of the Take-Along Page.

## Talk It Over

Ask youth some follow-up questions:

1. What are some **tools** you are familiar with?
2. What do you need to do to take care of the **tools** to make sure they last a long time? (*Rinse them off after use, store in a dry location and keep in good repair.*)
3. How do gardening **tools** make gardening easier?
4. What hand **tools** are difficult to learn to use?

## Seeds for More Growth

1. Tour a flea market or an antique shop and look for old **tools**.
2. Ask youth what their favorite hand **tools** are and why.
3. Design a corn-picking or corn-planting **tool**.
4. Find and display **tools** that do more than one job (*for example a bottle opener, which might also open cans*).
5. Share books from home or the library about gardening.
6. Help with tasks at home that require the use of hand **tools**, such as hammering, sawing or making cookies.

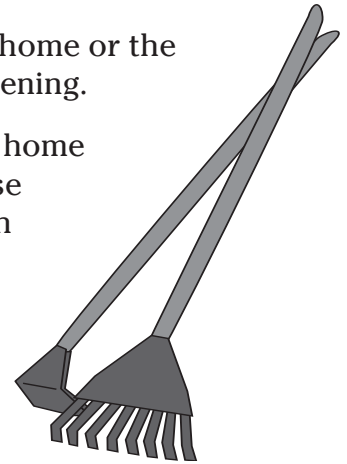

## Record Your Observations

Record new skills youth have learned, comments they make and ideas for next time:

---

---

---

---

---

---

---

---

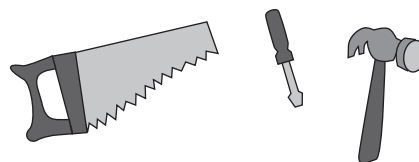



# Take-Along Page

## Activity 8: Tool Time

**Suggested Grade Level:**  
**1st Grade**

Use this space to draw some tools that you have around the house, or design your own.

**Q:** Why shouldn't you tell secrets on a farm?

**A:** Because the corn has ears, the potatoes have eyes and the beans talk.

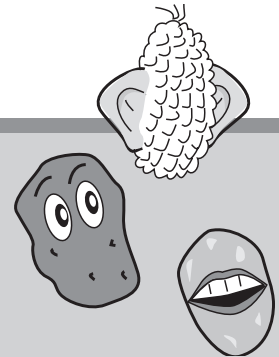

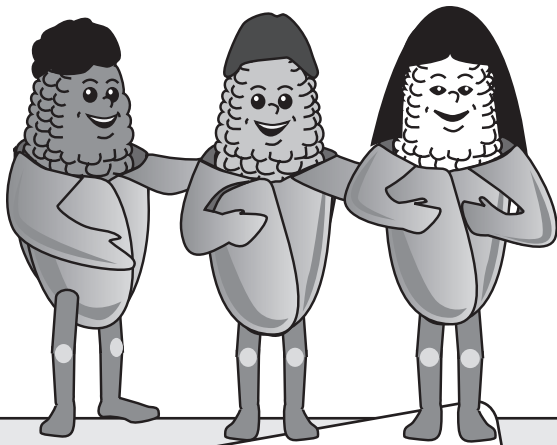

# Discover a Culture

## Dear Helper:

In this activity, youth will learn about a different culture. They will practice cultural interaction and cultural appreciation. After completing the activity, youth will be able to identify and describe at least one cultural difference or similarity.

## Clues About Kids

Show a positive attitude toward other cultures. Children pick up on the stereotypes and criticisms that some adults have formed about groups with different values and beliefs. Try to use facts and make nonjudgmental statements that show you value everyone, regardless of culture, such as, "This culture uses the food they grow."

## Time Involved

One or more meeting sessions for speakers to visit

## Suggested Group Size

Any size



## Materials Needed

Copies of Take-Along Page,  
one per youth



List of sample interview questions  
(see end of activity)



Suggested list of contact people  
(adult helper compiles from local resources)

## Vocabulary

**ethnology:** the study of living cultures

**culture:** the behavior patterns, customary beliefs, social forms, material traits and historical artifacts of a racial, ethnic, religious, or social group, transmitted over generations

## Activity Resources

- *Crazy About Corn* video tape, "Cooking Corn", "Tooling Along" and "Lend an Ear" segments
- *Crazy About Corn* audio tape, "Do You Know" song

## Putting Down Roots

Corn has been grown by many different **cultures** over thousands of years. Just as corn has grown and spread, different **cultural** groups have spread throughout the United States.

Communities are a diverse group of people, with many different languages, customs and attitudes. By exploring your own communities, you can better understand your own **culture** and begin to appreciate and form cross-**cultural** connections.

**Ethnology** is the study of living **cultures**. Researchers gather information from interviews, observations, historical artifacts and data. They use this information to create an accurate record of a **culture**. By examining records from different time periods, scientists can note changes in **cultural** practices.

Investigate local resources relating to **cultural** groups. You could explore your community's roots in Native American **cultures**. Possible resources include your public library, chamber of commerce, historical society, or a university's museum and Native American studies department. Make initial contacts and compile a list of possible people you could invite to speak to your group; in selecting speakers, try to include a range of ages.

Tell youth they will be listening to people talk about their **cultures**.

## Do It Now

1. Tell youth to take turns asking questions of your guest speakers (*see sample interview questions on next page*).
2. Review the new vocabulary.
3. Distribute copies of the Take-Along Page.

## Talk It Over

Ask youth some follow-up questions:

1. What did you learn about someone's **culture**?
2. What are some things that you have in common or feel differently about?
3. How are all members of a **cultural** group unique?

## Seeds for More Growth

1. Discuss with your family what they believe in and what your **culture** is.
2. Visit an **ethnic** restaurant or market.
3. Invite someone from a different **cultural** group to visit and give a demonstration on how to prepare food.
4. Choose a grain (corn, wheat, rice, etc). Find out how different **ethnic** groups prepare recipes for the grain. Have a potluck meal.
5. Read a story about a **cultural** group that lives in your area, either one who settled there a long time ago or one who moved there recently.



# Sample Interview Questions

- 1. What place, community or village did your family come from? Why did they decide to move to where you now live?
- 2. What does your family think are the biggest differences between where they came from and where they live now?
- 3. What does your family miss most about where they came from?
- 4. What traditions do your family observe?
- 5. Does your family eat corn? If so, how do they prepare it? Do you have a favorite corn recipe?
- 6. Do you have any family items that are old?
- 7. Are boys and girls treated differently in the area where your family came from? If so, how?

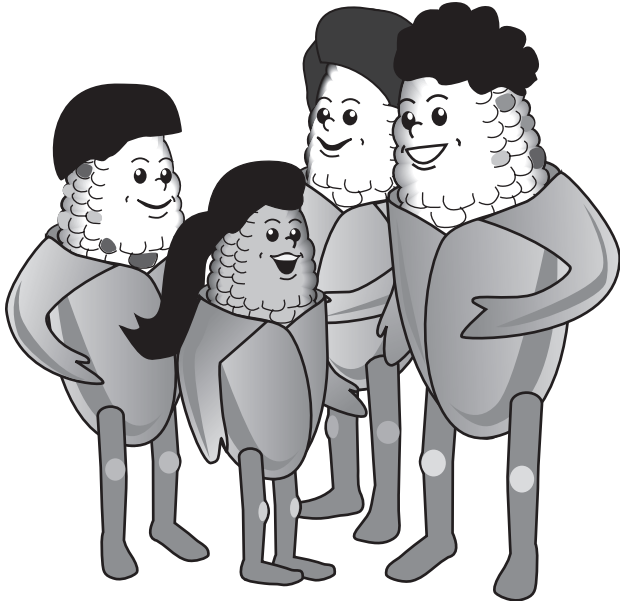

## Record Your Observations

Record new skills youth have learned, comments they make and ideas for next time:

---

---

---

---

---

---

---

---

---

---

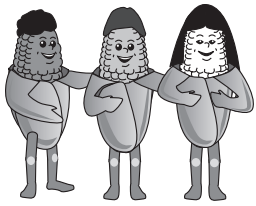

# Take-Along Page

**Activity 9:**  
Discover a Culture

---

**Suggested Grade Level:**  
**1st Grade**

Visit a local park and draw a picture of what you see other families doing.



**Q:** Why did the corn kernel join the army?

**A:** So he could travel far a-field.

---

Programs and activities of the Cooperative Extension Service are available to all potential clientele without regard to race, color, sex, national origin or handicap. This page is reproducible under the copyright agreement for youth participants and their families.

# Say It with Sand

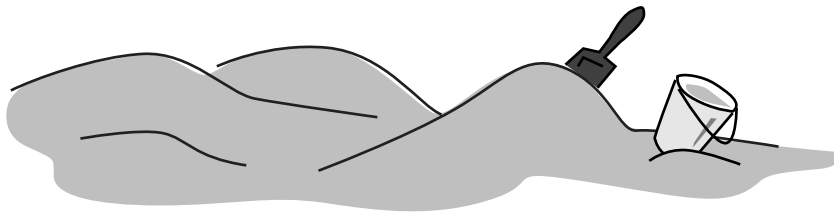

## Dear Helper:

In this activity, youth will make a sand painting. They will practice creative expression through art and cultural appreciation. After completing the activity, youth will be able to identify at least one material used in creating art.

## Clues About Kids

*Emphasize what to do rather than what not to do.* Offer guidance in a positive way. For example, say “Use the sand and water on your paper” instead of “Don’t flick water on your neighbor”; or say “Try using the chalk with the sand” instead of “You’re not finished with your picture yet.”

## Time Involved

About 15 minutes

## Suggested Group Size

Any size

## Materials Needed

- ✓ Copies of Take-Along Page, one per youth
- ✓ 6-inch x 8-inch sheets of coarse-grit sandpaper, one or more per youth
- ✓ Colored chalk, four sticks per youth
- ✓ Small cups of water, one per youth
- ✓ Sand-painting symbols found in Native American art books (optional)
- ✓ Dried grits, 1 tablespoon per youth
- ✓ Glue, one bottle per group

## Vocabulary

**ceremony:** set of acts created through ritual or custom and performed on specific occasions

**symbol:** a thing that represents something else

## Putting Down Roots

Sand paintings are a type of Native American art. Traditionally, sand paintings are made on the ground using colored sand and are destroyed after use.

Discuss the importance of **symbols** in art and the purposes of **ceremonial** art.

Tell youth they will be making a kind of sand painting using sandpaper and wet chalk.

## Do It Now

1. Distribute the sandpaper, chalk and cups of water. Give directions to youth: Dip the chalk in water and draw a picture. Use glue to make a design. Sprinkle grits on top. Shake off excess grits when glue is dry. (Younger children may want to draw whatever they like and make several pictures.)
2. Design suggestions: a corn field; a copy of the **symbolic** representations found in Native American sand paintings; family members; an important occasion in a youth's life.
3. Review the new vocabulary.
4. Distribute copies of the Take-Along Page.

## Talk It Over

Ask youth some follow-up questions:

1. What materials do you like for creating art?
2. Is traditional sand painting a good way to record information that you want to last a long time? (*Paper lasts longer and can be stored easily.*)

## Activity Resources

- *Crazy About Corn* video tape, "Kids Create" and "Lend an Ear" segments
- *Crazy About Corn* audio tape, "Peek-a-Boo" and "Ancient Corn Chant" songs

1. Invite an artist or a historian familiar with sand painting to discuss sand painting with your group.
2. Discuss what things you do (decorations, food, etc.) to celebrate special occasions.
3. Use colored chalk to draw **symbols** on other surfaces, such as black construction paper or the sidewalk.
4. Visit the library to find examples of other Native American **ceremonial** art.

## Record Your Observations

Record new skills youth have learned, comments they make and ideas for next time:

---

---

---

---

---

---

---

---



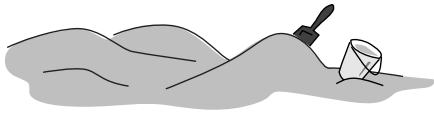

# Take-Along Page

**Activity 10:**  
Say It with Sand

**Suggested Grade Level:**  
**1st Grade**

As a family, go to a local museum or library and learn about a Native American group that lives near you.

Write the group's name and one of their traditions here:

Native American group: \_\_\_\_\_

A tradition of the group: \_\_\_\_\_

\_\_\_\_\_

\_\_\_\_\_

\_\_\_\_\_

\_\_\_\_\_

\_\_\_\_\_

\_\_\_\_\_

\_\_\_\_\_

\_\_\_\_\_

\_\_\_\_\_

**Q:** What did Carolyn Cornstalk say to Richie Cornstalk on his birthday?

**A:** How many ears old are you?

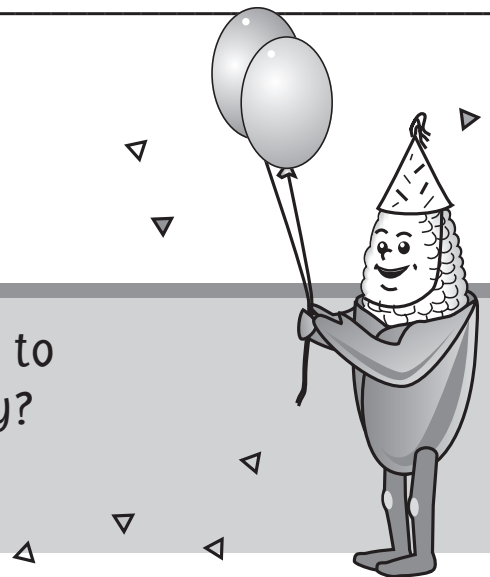

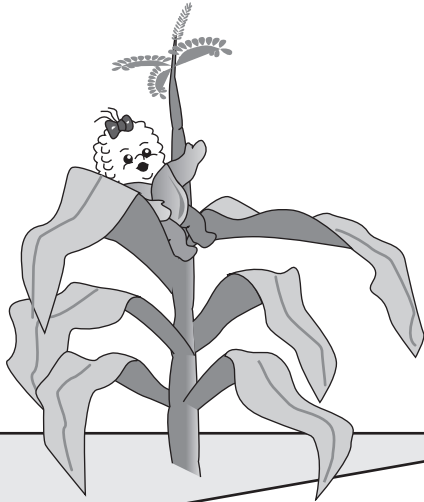

# Corn Is Born



## Dear Helper:

In this activity, youth will listen to a poem and interpret its meaning. They will practice comprehension skills and listening. After completing the activity, youth will be able to demonstrate one way to interpret a poem.

## Clues About Kids

Help children think of images. Children can think of ways to illustrate the verse by answering your leading questions, such as, “What picture did you get in your mind when you read the verse?” or “Did the verse remind you of anything you have seen or done with your family?”

## Time Involved

About 20 minutes

## Suggested Group Size:

Any size

## Materials Needed

- ✓ Copies of Take-Along Page, one per youth
- ✓ “The Roots of Corn” poem, one copy per youth (see end of activity)
- ✓ Props and prop-making material (helper and youth determine what to use)

## Vocabulary

**verse:** a group of lines of a poem or song

**poem:** a kind of writing that is something like a song without music; poems often use special words that rhyme and have unique ways of putting words together to tell about feelings and thoughts

## Activity Resources

- *Crazy About Corn* video tape, “Lend an Ear” segment
- *Crazy About Corn* audio tape, “Peek-a-Boo,” “Corn Is Maize,” “Corn Ear Sing-Along,” “Ancient Corn Chant” and “Mexico” songs and “Roots of Corn” poem

## Putting Down Roots

**Poems** have a way of helping us to create pictures in our mind. These pictures are different for each of us because we all have different backgrounds and experiences.

Tell youth they will listen to a **poem** and represent something expressed in one of the **verses**.

## Do It Now

1. Read the **poem**, “The Roots of Corn” (see page 56). Divide the class into partners or larger groups. Give the groups a single **verse** to read and think about. Ask them to make a drawing, perform an action or show a prop that they think best represents that **verse**. For example, if using this **verse**,

*In tortillas I'm crunchy;  
In puddings I'm creamy;  
When hot off the cob I'm chewy and  
steamy.*

Youth might draw a picture to represent a tortilla, a bowl of pudding or corn on the cob, or they may crinkle paper to represent the sound of “crunchy.”

2. When all groups are ready, gather them together and read the **poem** again. Ask each group to show what they think represents the **verse** and explain why.
3. Review the new vocabulary.
4. Distribute copies of the Take-Along Page.

## Talk It Over

Ask youth some follow-up questions:

1. What is your favorite line in the **poem**?
2. How does the **poem** talk about corn?

## Seeds for More Growth

1. Individually or in a group, create a **poem** about another food.
2. Dramatize other **poems** or stories. Perform the dramatization for a group.
3. Make a book of youths’ first homes. Push pins onto a map showing the various locations where youth have lived.

## Record Your Observations

Record new skills youth have learned, comments they make and ideas for next time:

---

---

---

---

---

---

---

---

---

---

---

---

---

---

---

---

---

---

---

---

---

---

---

---

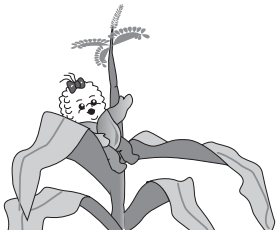

# Take-Along Page

## Activity 11: Corn is Born

**Suggested Grade Level:**  
**2nd Grade**

Read these first and last stanzas from “The Roots of Corn” poem.  
Then make up your own family poem about corn.

### The Roots of Corn

©1997, LaVerne Kennevan Maginnis

In tortillas I’m crunchy;  
In puddings I’m creamy;  
When hot off the cob  
I’m chewy and steamy.

I come in six different colors:  
Black and yellow  
and speckled hues.  
Can you guess what my other  
colors could be?  
Think America—red,  
white and blue.

### Family poem:

---

---

---

---

---

---

---

---

---

---

**Q:** Roses are red. Violets are blue.  
Corn is yellow, but what can it do?

**A:** To find out the answer, read  
“The Roots of Corn” poem.

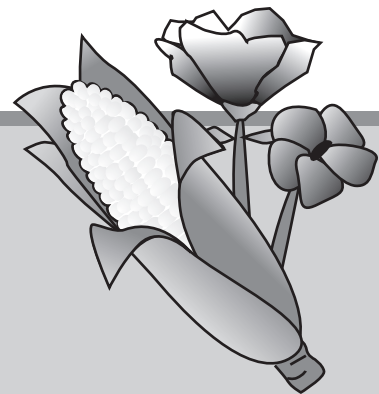

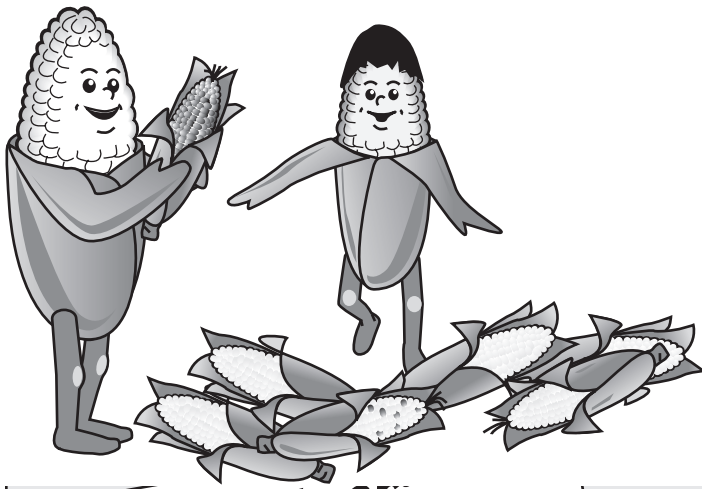

# Harvest Hooplah!

## Dear Helper:

In this activity, youth will plan a harvest celebration. They will practice cultural awareness and social interaction. After completing the activity, youth will be able to identify at least one reason for holding a harvest festival.

## Clues About Kids

*Help children respect new ideas.* Children may not want to try new foods. Say “Taste it. If you don’t like it, you don’t have to eat any more. You only have to give it one try.” This approach exposes children to new foods while giving them a choice over what they eat and don’t eat.

## Time Involved

About 25 minutes

## Suggested Group Size

Any size

## Materials Needed

✓ Copies of Take-Along Page, one per youth

✓ Books and information about a variety of cultures that celebrate harvest time

## Vocabulary

**interdependence:** trusting and relying on each other

**appreciation:** understanding and respecting the importance of something or someone

## Activity Resources

- *Crazy About Corn* video tape, “Lend an Ear” segment
- *Crazy About Corn* audio tape, “Immigrant Song,” “Corn Ear Sing-Along” and “Blue Corn Blues” songs

## Putting Down Roots

Fall in North America has always been a harvest time. We have the opportunity to experience the ways in which different cultures celebrate their times of bounty and plentiful harvest.

Many cultural groups celebrate through harvest festivals. Each celebration has unique features. Common themes are found throughout: gratitude for the harvest, the **interdependence** of people and nature, and **appreciation** for people who cultivate the land. Harvest festivals traditionally include a gathering of friends and relatives.

Before planning your harvest festival, research and gather materials from a variety of sources showing different harvest celebrations.

Celebrations might include Canadian or American Thanksgiving, "Kwanzaa" (an African-American harvest festival begun in 1966) or "Sukkoth" (a Jewish harvest festival).

Pictures, recipes, music and storybooks from many cultures will help youth to **appreciate** different cultures and their celebrations. Include both contemporary and historical information.

Tell youth they will be planning a harvest celebration.

## Do It Now

1. Plan a harvest festival. Make a menu. Choose decorations and music. Prepare a guest list.
2. Review the new vocabulary.
3. Distribute copies of the Take-Along Page.

## Talk It Over

Ask youth some follow-up questions:

1. How are harvest festivals like other holidays you celebrate? (*Many events celebrate shared memories and beliefs.*)
2. What other foods could be included in a celebration?
3. How is carrying on a tradition important to a group?

## Seeds for More Growth

1. Carry out the festival you have planned.
2. Discuss what you are thankful for.
3. Visit a festival in your area and document some of the main ideas through photos, drawings or interviews.
4. Brainstorm to come up with ideas on how new celebrations are developed.
5. Illustrate the seven principles of Kwanzaa. Assemble drawing pages to form a book. Plan a celebration meal including traditional African foods.
6. Participate in a world hunger project.

## Record Your Observations

Record new skills youth have learned, comments they make and ideas for next time:

---

---

---

---

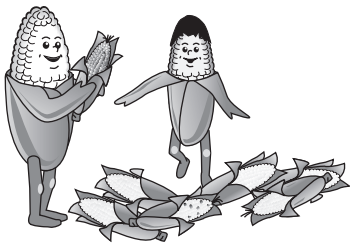

# Take-Along Page

**Activity 12:**  
Harvest Hooplah!

**Suggested Grade Level:**  
**2nd Grade**

Use the space below to draw a picture of how you would decorate your table for the harvest festival.

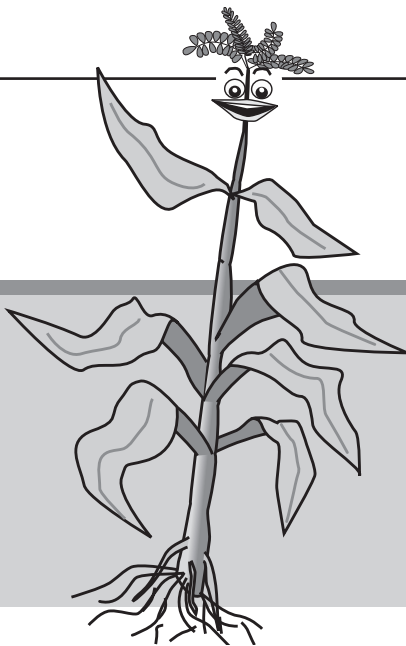

**Q:** How do you know a cornfield is friendly?

**A:** It waves at you when it's windy outside.

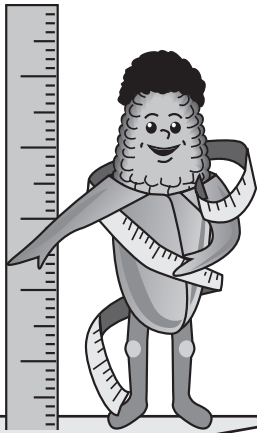

# Corn Measures Up!



## Dear Helper:

In this activity, youth will use measurement tools to measure several items. They will practice counting skills and eye-hand coordination. After completing the activity, youth will be able to identify at least one unit of measurement (for example inch, foot, yard).

## Clues About Kids

Let children answer their own questions. Adults don't need to have all the answers. Children may ask a question such as, "Where did the word yard come from?" Ask the children what they think. How could they find the answer? Children learn more from what they discover themselves than from what adults tell them.







## Time Involved

About 20 minutes

## Suggested Group Size

Four per group

## Materials Needed

-  Copies of Take-Along Page, one per youth
-  Copies of "Measurement Chart" (see end of activity), one per youth
-  Rulers, one per group
-  Paper, one sheet per youth
-  Yardsticks, one per group
-  Pencils, one per youth
-  Tape measures, one per group

## Vocabulary

**foot:** unit of measurement equal to 12 inches

**yard:** unit of measurement equal to 3 feet



## Putting Down Roots

Ask one or two youth how tall they are in feet and inches.

Show rulers, yardsticks and tape measures as different tools for measuring.

Explore the differences in the height of several objects, using the terms “inch,” “foot” and “yard.”

Demonstrate how to measure height by measuring one youth from each group.

Tell youth they will be measuring items, areas and people in your meeting space.

## Activity Resources

- *Crazy About Corn* video tape, “Lend an Ear” segment
- *Crazy About Corn* audio tape, “Growing Up Fast” and “What Matters Most of All” songs

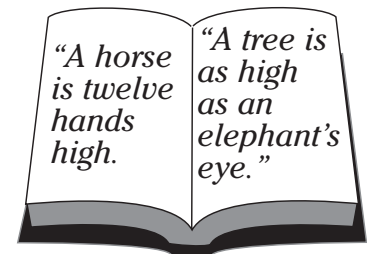

## Do It Now

1. Distribute copies of the “Measurement Chart.” Allow youth to measure several items, areas and people, and record numbers on the sheet.
2. Review the new vocabulary.
3. Distribute copies of the Take-Along Page.

## Talk It Over

Ask youth some follow-up questions:

1. When you measured items, did each person in your group come up with the same size? Why or why not?
3. Which is easier to use, a hard ruler or a tape measure?
4. Why do we need to know how tall something is?

## Seeds for More Growth

1. Find a book about expressions involving measurement, or ask adults around you if they can recall any. Discuss as a group.
2. Measure a brother, a sister, a friend or an adult.
3. Design a growth chart to hang on a wall at home. Start your chart by standing straight against the wall and asking a parent to mark your height and the date of measurement.
4. Find as many measuring devices as you can at home or in your meeting place.

## Record Your Observations

Record new skills youth have learned, comments they make and ideas for next time:

---

---

---

---

## Measurement Chart

1. Measure how tall one person is in your group:

name \_\_\_\_\_ height \_\_\_\_\_

2. Measure a tile on the floor: \_\_\_\_\_ long \_\_\_\_\_ wide

3. Measure a book: \_\_\_\_\_ long \_\_\_\_\_ wide

4. Measure a plant in the room:

plant name \_\_\_\_\_

\_\_\_\_\_ long \_\_\_\_\_ wide

5. How tall are you? height \_\_\_\_\_

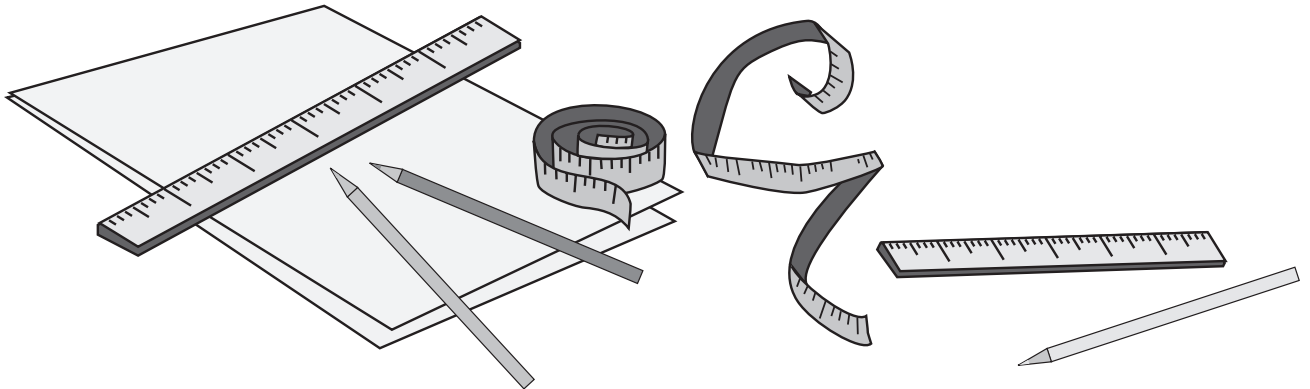

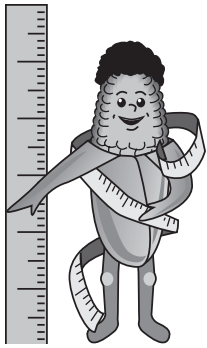

# Take-Along Page

**Activity 13:**  
Corn Measures Up!

**Suggested Grade Level:**  
**2nd Grade**

Measure some people and furniture in your house.  
Record the measurements here.

Name \_\_\_\_\_  
height \_\_\_\_\_

Name \_\_\_\_\_  
height \_\_\_\_\_

Name \_\_\_\_\_  
height \_\_\_\_\_

furniture (*what kind?*) \_\_\_\_\_  
long \_\_\_\_\_ wide \_\_\_\_\_

furniture (*what kind?*) \_\_\_\_\_  
long \_\_\_\_\_ wide \_\_\_\_\_



## **Tongue Twister:**

How many husks could a corn husker husk  
if a corn husker could husk corn?



# Blue Corn Blues



## Dear Helper:

In this activity, youth will listen to the “Blue Corn Blues” song on the Crazy About Corn audio tape, discuss the words and write a song to convey their own experiences and emotions. They will practice music appreciation and social interaction. After completing the activity, youth will be able to portray at least one emotion found in song.

## Clues About Kids

*Listen to uncover children’s feelings.* The feelings behind what children say are as important as the words they say. For example, a child might say, “I don’t care when someone picks on me. It doesn’t hurt.” Respond with a comment to uncover the child’s feelings, such as, “Well, it sure would make me angry.” Whether you are right or wrong about the angry feeling behind the words, listening and responding will encourage the child to keep talking about the experience.







## Time Involved

About 40 minutes

## Suggested Group Size

Any size (the song writing can be done in pairs or small groups)

## Materials Needed

-  Copies of Take-Along Page, one per youth
-  “Blue Corn Blues” song on *Crazy About Corn* audio tape
-  Tape player
-  Paper, one sheet per group
-  Pencils, one per youth
-  Posterboard, one sheet
-  Markers, two or three

## Vocabulary

**blues:** music expressing melancholy, a slow jazz rhythm

## Putting Down Roots

People have traditionally sung the **blues** while working and for entertainment. This music tells a story and portrays sad emotions.

Gather materials and make copies of words to the song.

Tell youth they will be listening to a **blues** song, discussing the words and rewriting the words to convey their own experiences and emotions.

## Activity Resources

- *Crazy About Corn* video tape, “Lend an Ear” segment
- *Crazy About Corn* audio tape, “Blue Corn Blues” song

## Do It Now

1. Play “Blue Corn Blues.” Discuss the emotions in the song. Emphasize the repetition in the chorus. Ask “How does it feel to be picked on?”
2. Divide youth into pairs or small groups. (You may want to pair younger with older youth.) Ask each pair or group to write a new stanza of “Blue Corn Blues”. Collect the stanzas and write them on the posterboard. Try singing the stanzas as a group. Repeat the chorus of “Blue Corn Blues.”
3. Review the new vocabulary.
4. Distribute copies of the Take-Along Page.

## Talk It Over

Ask youth some follow-up questions:

1. How is writing a song like writing a story? (*Songs tell a story with rhythm.*)
2. What other feelings could you express with a song? (*excitement, happiness, anger*)



## Seeds for More Growth

1. Listen to a recording or invite a musician to perform for your group. Discuss.
2. Discuss what you do when you feel **blue**.
3. Discuss other songs you know that portray feelings (for example “If You’re Happy and You Know It”).
4. Try out instruments used in playing the **blues** (for example saxophone, piano, trumpet, clarinet), then discuss the different sounds they make.

## Blue Corn Blues

*by Bob Diven*



"Well I woke up this morning  
Hangin' out on my stalk.  
Tired a' bein' picked on,  
I went to take a walk.  
I've got them blue corn blues.  
I'm blue as a corn cob can be.  
Hey Mister Cornpicker, why you  
always pickin' on me?

I'm tasty, yes delicious,  
But I'm mighty hard to grow.  
Come along, sing with me  
as I travel down this row.  
I've got them blue corn blues.  
I'm blue as a corn cob can be.  
Hey Mister Cornpicker, why you  
always pickin' on me?

## Record Your Observations

Record new skills youth have learned, comments they make and ideas for next time:

---

---

---

---

---

---

---

---

---

---



# Take-Along Page

## Activity 14: Blue Corn Blues

**Suggested Grade Level:**  
**2nd Grade**

List several things that make you and the other members of your family blue, and several things that make you and your family happy:

Things that make us blue:

---

---

---

---

---

---

---

---

---

---

Things that make us happy:

---

---

---

---

---

---

---

---

---

---



### Tongue Twister

What kind of horn would blue corn blow  
if blue corn could blow horns?

## Additional Resources

You may want to check out these and other books from your local library to share with the children as supplemental information for their enjoyment and learning. (Prices listed are current at the time of printing and are subject to change.)

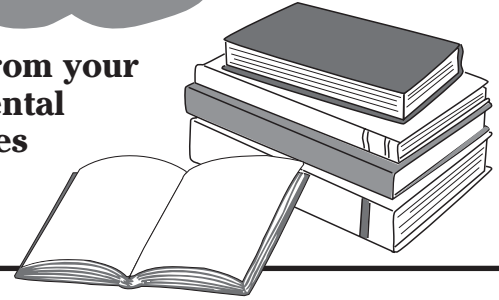

Aliki. *Corn Is Maize: The Gift of the Indians*. Harper Collins Publishers, New York, 1976. Simple description of how corn was discovered and used by Native Americans and how it came to be an important food throughout the world. Very informative. Good illustrations. 33 pages. Ages 5–8. \$4.95

Arnosky, Jim. *Raccoons and Ripe Corn*. Lothrop, Lee and Shepard Books, New York, 1987. Good illustrations of wildlife enjoying corn in the evening. Ages 5–8. \$4.95

Bartok, Mira, and Christine Ronan. *Pueblo Indians of the Southwest*. Good Year Books, Illinois, 1996. Where the Pueblo people live, important crops and activities. Good photographs. 16 pages. Ages 5–8. \$4.95

Bial, Raymond. *Corn Belt Harvest*. Houghton Mifflin Co., Boston, 1991. Text and photographs describe the United States Corn Belt region and its harvest season. Very informative. 47 pages. Ages 5–8. \$14.95

Caduto, Michael J., and Joseph Bruchac. *Native Plant Stories*. Fulcrum Publishing, Golden, Colorado, 1995. Mythical stories drawn from the legends of 18 Native American tribes. 127 pages. Ages 8–12. \$12.95

Clark, Ann Nolan. *In My Mother's House*. Penguin Group, New York, 1992. Collection of poems by Tewa children. 56 pages. Ages 5–8. \$4.99

Dubowski, Cathy East. *Squanto, First Friend to the Pilgrims*. Yearling Book, New York, 1990. Squanto played an important role in making peace between Native Americans and the settlers at Plymouth. True story. Good illustrations. 91 pages. Ages 5–8. \$3.50

Fowler, Allan. *Corn: On and Off the Cob*. Children's Press, Chicago, 1994. Narrative story on everything about corn: who eats it, parts of the corn stalk and how Native Americans were the first to raise corn. Good photographs. 31 pages. Ages 5–8. \$3.95

Gerson, Mary-Joan. *People of Corn, A Mayan Story*. Little, Brown, and Co., New York, 1995. Mayan gods used sacred corn to reward people who would thank and praise their creators. Corn was the spirit of life. Good illustrations. 28 pages. Ages 5–8. \$15.95

Gonzalez-Jensen, Margarita. *Tortillas*. Scholastic Inc., New York, 1994. Beginning literacy. Simple, easy-to-read story. 16 pages. Ages 5–6. \$3.95

Hudson, Cheryl Willis. *Bright Eyes, Brown Skin*. Just Us Books, Orange, New Jersey, 1990. Book about color and cultures. Good illustrations. 23 pages. Ages 5–8. \$12.95

Kellog, Cynthia. *Corn: What It Is, What It Does*. Greenwillow Books, New York, 1989. Comprehensive corn story. Explains Native Americans' early involvement in cultivating corn. Good illustrations. 47 pages. Ages 5–8. \$11.88

Ketteman, Helen. *The Year of No More Corn*. Orchard Books, New York, 1993. Beanie's grandpa tells him about the failure of the corn crop in 1928, and how he was able to make corn trees grow from whittled corn kernels. Good illustrations. 27 pages. Ages 5–8. \$14.95

Paola, Tomie de. *The Popcorn Book*. Scholastic Inc, New York, 1978. Fictional story of how popcorn was discovered. 27 pages. Ages 5–8. \$2.95



# The Roots of Corn

©1997, LaVerne Kennevan Maginnis

In tortillas I'm crunchy;  
In puddings I'm creamy;  
When hot off the cob I'm chewy and steamy.

I'm baked into muffins;  
I'm fried to make mush;  
And once in the popper you can't make me hush.

You'll find me in syrup;  
You'll taste me in soup;  
Or munch me in cereal, scoop after scoop.

Have you guess who I am yet?  
Of course you have—corn!  
But what do you know about how I was born?

Do you know what I'm used for?  
And where I can grow?  
Would you like to learn more now?  
Ready, set, go!

I don't remember exactly  
When and where I started to grow,  
But I think it was eight thousand years ago  
In the land we now call Mexico.

It was then a wild grass, not planted,  
Not sown by machine or by hand.  
The wind blew and carried and scattered my seeds  
Over stretches of fertile land.

Back then I looked very different  
From the way you know me today:  
No kernels in clusters or layers of husk,  
No cob or long tassels, they say.

For the way I look and I grow now  
We can thank the farmers of old—  
They saved the best kernels from every new crop  
To create their harvest of gold.

With care they planted my kernels  
Away from where the wild grasses grew.  
In crop after crop I got stronger and better—  
Those farmers know just what to do.

Native Americans grew me  
Some three thousand years gone by.  
Working hard, they found ways to cultivate maize  
In soils soft, hard, wet or dry.

To them I was so important,  
Each tribe had its own name for me—  
"Our Mother," "Our Life" and "Seed of the Seeds"  
Come to mind, to name only three.

Some of the tribes used to worship me.  
Some still speak of me when they pray.  
Others make dolls in the likeness of corn gods;  
These represent life, so they say.

Europeans did not even see me  
Till the year 1492,  
When Columbus explored the Americas  
(Cuba and Haiti) with his crew.

While searching for gold and spices  
Over many long nights and days,  
They saw fields of corn and met friendly  
people  
Who gave the men gifts—ears of maize.

I helped the first English settlers,  
Going back some three hundred years,  
When the Mayflower Pilgrims needed some food  
To live through their first winter here.

Today I have many more uses—  
In powders and starches, it's true,  
And in medicines, paints and textiles as well;  
Paper products and gasoline, too.

Of every hundred bushels of corn,  
You people eat only fifteen.  
All the rest goes to feed livestock  
And uses like those you've just seen.

I'm grown in all of the fifty states.  
I'm the U.S.A.'s largest crop.  
Today I'm important around the world—  
In the African diet I'm tops.

Through the colonists and explorers,  
I passed into fields far and wide—  
Into Africa, Asia and Europe as well;  
Almost everywhere people reside.

I come in six different colors:  
Purple, yellow and speckled hues.  
Can you guess what my other colors could be?  
Think America—red, white and blue.



# TEACHERS' RESOURCE BOOK

This "Crazy About Corn" curriculum guide is designed as a teaching supplement to the "Crazy About Corn" educational multimedia program. A variety of developmental skills are incorporated to enhance the learning of young students.

The activities can be carried out in many educational environments – classrooms, playgrounds, field trips, and home school settings. Broadly categorized, the activities relate to culture and society; science; and communication and expressive arts. If you find that some activities do not fit the needs or interests of your students, feel free to skip them. Most activities can be done in any order.

The activities are indexed to various elements in the "Crazy About Corn" multimedia package and include suggested grade levels. Certain activities relate to the original songs contained on the website and videos. The activities and tips are provided to make your job easier and to increase the success of the youth involved.

## **Educational Products from Educators:**

Crazy about Corn™ products are developed by New Mexico State University Cooperative Extension Service education and research professionals.

<http://mediaproductions.nmsu.edu>

<http://aces.nmsu.edu/crazyaboutcorn>



©1999, NMSU Board of Regents and its licensors.  
All rights reserved. Crazy About Corn™ is a  
trademark of New Mexico State University  
Cooperative Extension Service.

